

## CCT

Sliders with four rollers, arranged in pairs, maintain the preload over the entire rail length. Pivoting roller mounts coupled with concentric and eccentric rollers allows for a smooth operation over complex rail layouts.

Slider in stainless steel is available as an option, contact Rollco for more information.

We customize each application according to drawing.

See document Technical Information for further details.

Dimensions in mm.

Please contact us for CAD-files.



## General Data

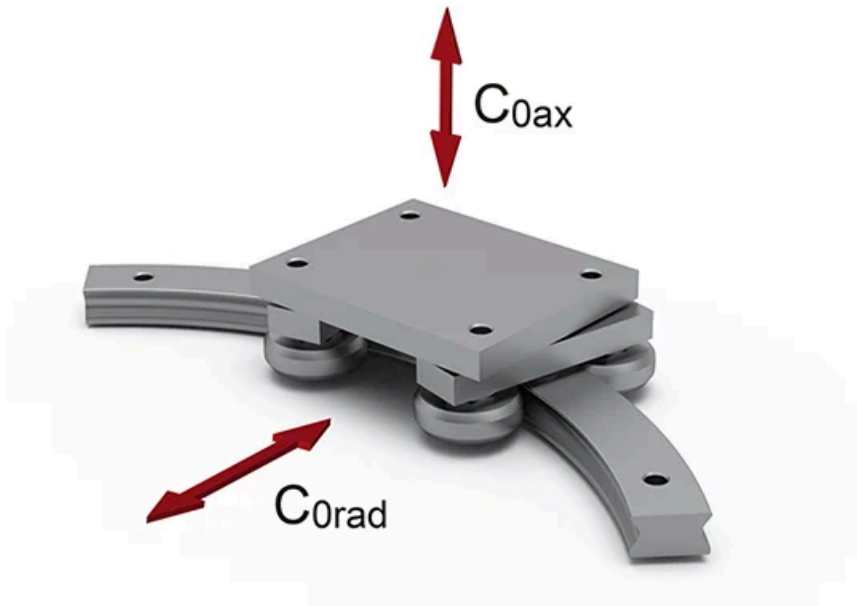

| Designation | Weight (kg) | Load Capacity C0ax (N) | Load Capacity C0rad (N) |
|-------------|-------------|------------------------|-------------------------|
| CCT08       | 0.45        | 400                    | 570                     |
| CCT11       | 1.10        | 1130                   | 1615                    |

## Dimensions

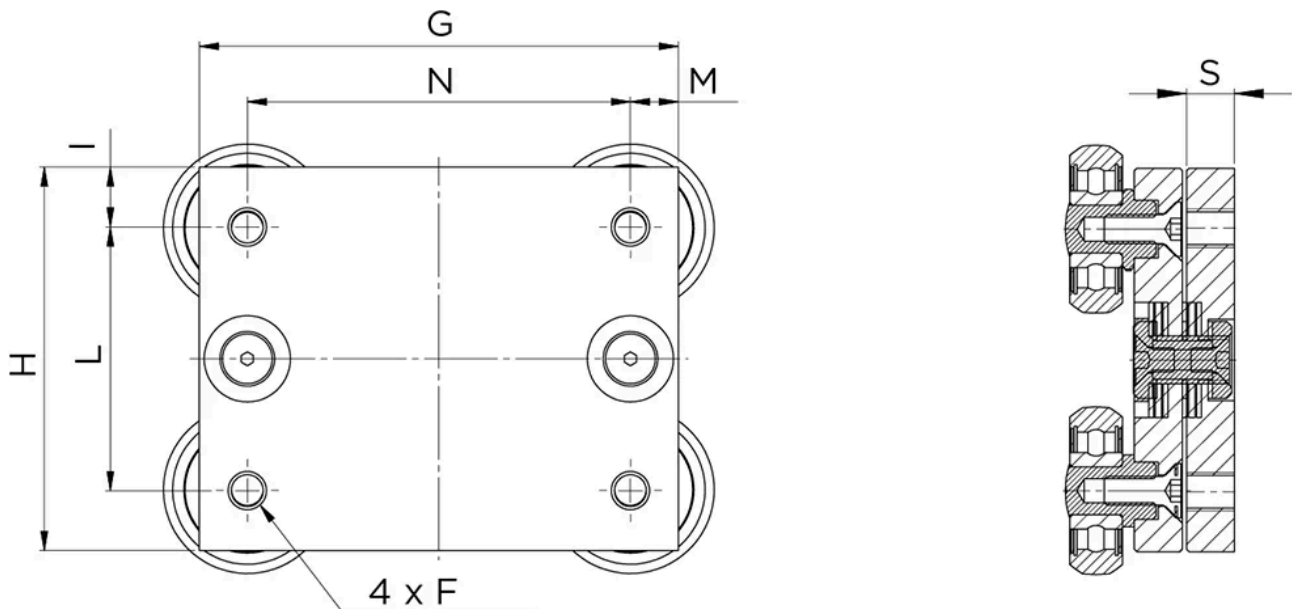

| Designation | F  | G   | H  | I    | L  | M  | N  | S  |
|-------------|----|-----|----|------|----|----|----|----|
| CCT08       | M5 | 70  | 50 | 10   | 30 | 10 | 50 | 10 |
| CCT11       | M8 | 100 | 80 | 12.5 | 55 | 10 | 80 | 10 |