

Linear Unit QME

QME is a ready to mount positioning table guided with linear ball bearings on hardened shafts and driven by ball- or lead screw. QME can be manually driven by handwheel using either ball screw or lead screw. For drive by motor, the ball screw versions are strongly recommended for sustained performance and precision.

Customized machining of the drive- and mounting interfaces, higher level of corrosion resistance or low/high temperature versions, please contact Rollco.

Bellow for Linear Unit QME is recommended for all applications where the unit isn't protected against dust and dirt. The bellow may also work as a pinch protection.

All dimensions in mm.

QME12: Max. L tot: 1 000 mm

QME20: Max. L tot: 1 500 mm

QME30: Max. L tot: 2 000 mm





General Data

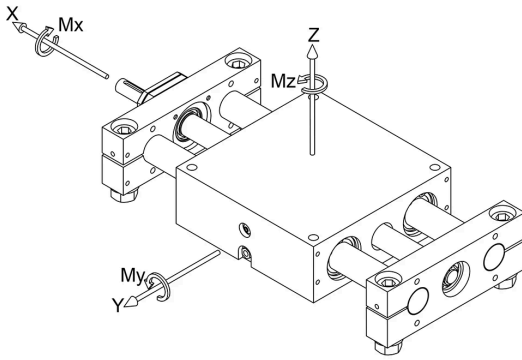

Permissible load Fz and Fy

Permissible load based on a shaft deflection of 1/1000 of Ltot. For long units, actual load may need to be reduced to achieve a deflection acceptable for the application.

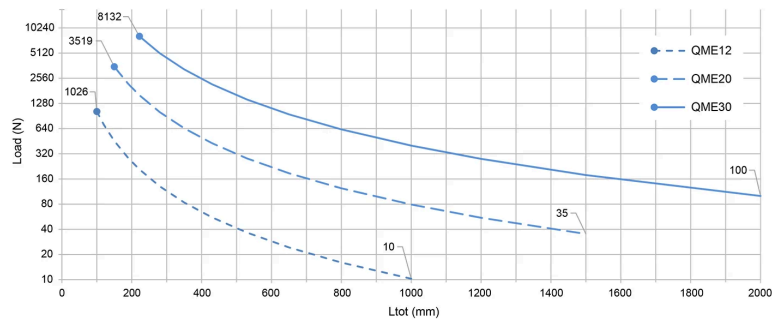

All capacity values are based on the individual ratings of the linear ball bearings used inside the QME and are without any safety factor. The usable load level depends on required service life and the system configuration. The safety factor depends on the application and its requested safety. We recommend a minimum dynamic safety factor 5.

Permissible load Fx

Permissible load is based on the buckling limit of the drive screw. For QME30, buckling will never occur due to the use of oversized drive screws.

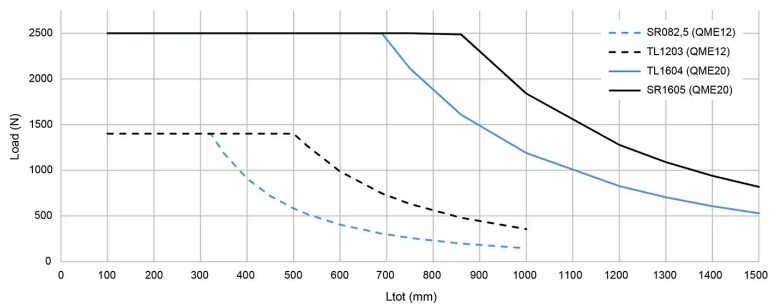
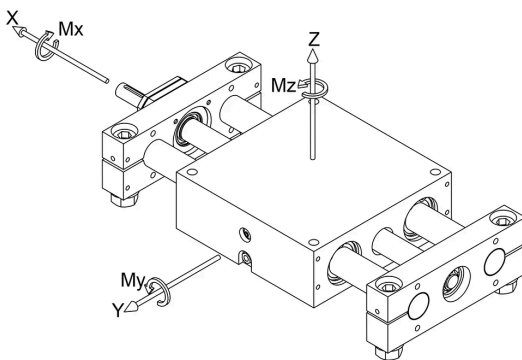

All capacity values are based on the individual ratings of the linear ball bearings used inside the QME and are without any safety factor. The usable load level depends on required service life and the system configuration. The safety factor depends on the application and its requested safety. We recommend a minimum dynamic safety factor 5.

Designation	Screw Type	Static Load Capacity Fz (N)	Dynamic Load Capacity Fz (N)	Static Load Capacity Fy (N)	Dynamic Load Capacity Fy (N)
QME12	SR082,5, TR1203, TL1203	3160	2080	3160	2080
QME20	SR1605, TR1604, TL1604	5600	3520	5600	3520

Designation	Screw Type	Static Load Capacity Fz (N)	Dynamic Load Capacity Fz (N)	Static Load Capacity Fy (N)	Dynamic Load Capacity Fy (N)
QME30	SR3205, SL3205, SR3210, SR3220, TR3006	11200	6400	11200	6400

Designation	Static Load Capacity Mx (Nm)	Dynamic Load Capacity Mx (Nm)	Static Load Capacity My (Nm)	Dynamic Load Capacity My (Nm)	Static Load Capacity Mz (Nm)	Dynamic Load Capacity Mz (Nm)
QME12	71	47	74	49	74	49
QME20	202	127	216	136	216	136
QME30	728	416	678	387	678	387

Designation	Dynamic Capacity Ca (N)	Permissible Fx (N)
QME12	2030 (n/a for TR)	1400
QME20	7100 (n/a for TR)	2500
QME30	9500 (n/a for TR)	3200

Dimensions

QME12

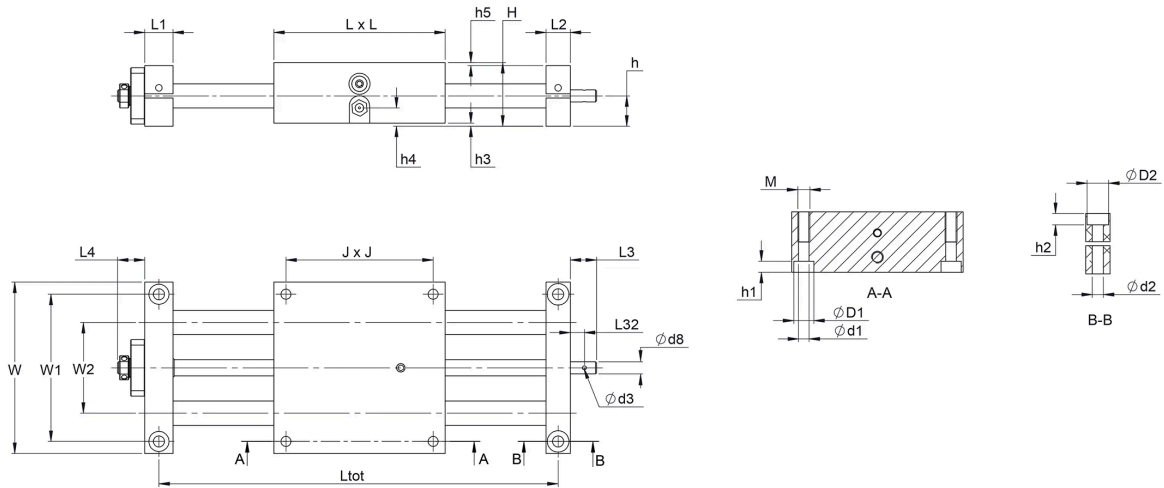

QME20 & QME30

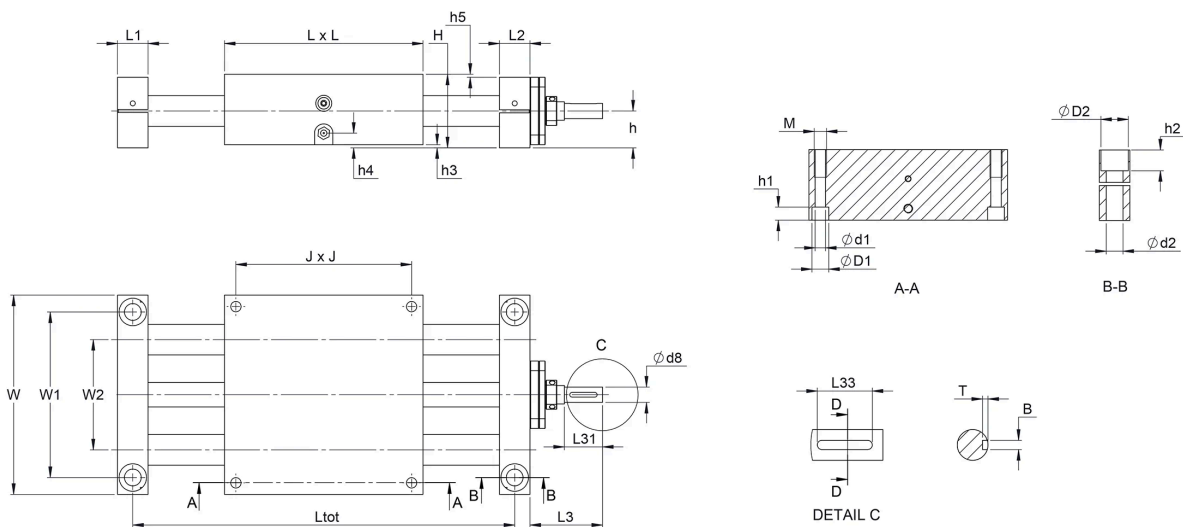

Stroke definition

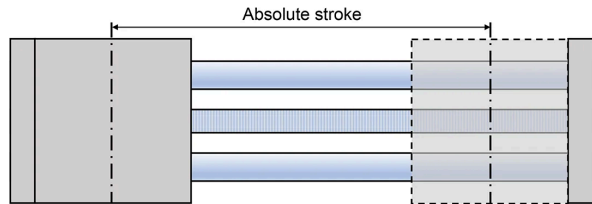

Working stroke: Is the working stroke of the application.
 Absolute stroke: Is defined as Working stroke + Stroke reserve.
 Stroke reserve: Is a safety distance to the mechanical end positions.

	Max. Ltot	Max. absolute stroke	
		no bellows	with bellows
QME12	1 000 mm	902 mm	693 mm
QME20	1 500 mm	1 350 mm	1 084 mm
QME30	2 000 mm	1 778 mm	1 493 mm

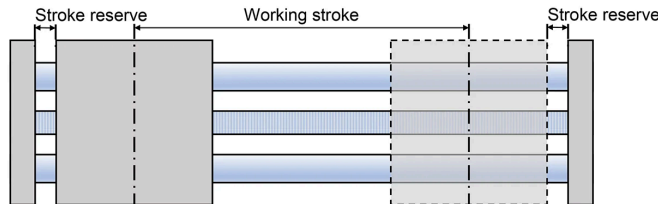

Designation	Ltot	Bellow Ltot	B (P9)x L33 x T	D1	d1	D2	d2	d3	d8
QME12	Absolute stroke +98	Absolute stroke *1.28+113	-	10	5.2	10	5.5	2	6 (h7)
QME20	Absolute stroke +150	Absolute stroke *1.23+166	3 x 18 x 1.8	11	6.8	18	11	-	10 (h7)
QME30	Absolute stroke +222	Absolute stroke *1.18+238	5 x 36 x 3	11	6.8	20	13	-	16 (h7)

Designation	H	h	h1	h2	h3	h4	h5	J	L	L1
QME12	31.5	15	5.5	5.7	1.5	7.5	1.5	73	85	12
QME20	48	24	8	13.5	2	7.5	2	115	130	20
QME30	71	36	8	14	2	15	1	184	200	22

Designation	L2	L3	L4	L31	L32	M	W	W1	W2
QME12	14	13	13.5	-	7	M6 x 15	85	73	45
QME20	20	47.5	-	25	-	M8 x 18	130	108	72
QME30	22	80	-	45	-	M8 x 20	200	178	130

Weight

Designation	Zero stroke (kg)	Moving part (kg)	+/100 mm stroke (kg)	Remark
QME12	1.02 / 1.04 with bellows	0.55 / 0.57 with bellows	0.22 / 0.28 with bellows	Masses may deviate +/- 5% depending on screw type and other options.
QME20	3.52 / 3.56 with bellows	1.76 / 1.80 with bellows	0.65 / 0.80 with bellows	Masses may deviate +/- 5% depending on screw type and other options.
QME30	12.3 / 12.4 with bellows	5.77 / 5.91 with bellows	1.73 / 2.04 with bellows	Masses may deviate +/- 5% depending on screw type and other options.