

PSS 31 - Shaft 8 mm solid

- Positioning system with IP 65
- Absolute measuring system, without battery
- Galvanically separated supply voltages between control and motor and bus
- Absolute encoder eliminates the need for reference runs during system setup and installation of replacements
- Easy address assignment directly on the device using integrated address switches (not for IO-Link)
- Regulation of the current torque prevents overloading and unnecessary run aborts
- Strong breakaway torque enables safe start-up even after an extended standstill
- Intelligent running behaviour. Recognises the difference between obstacles and dirt
- Spindle offset run: Excludes inconsistencies due to lash in the spindle.
- Condition monitoring of supply voltage, drag error (permits optimum adjustment of current position), power consumption and torque
- Partial safety function for STO (Safe Torque Off)



Dimensions in mm.

Type: Vertical

Nominal Torque (Nm): 1; 2; 5

Nominal Speed (rpm): 40; 115; 210

Nominal Voltage (V DC): 24 ($\pm 10\%$)

Nominal Current (A): 2.2

Output Shaft (mm): 8

Output Shaft Type: Solid

BUS Communication: Can Open (CA); Profi Bus (DP); Device Net (DN); Modbus (MB); IO-Link (IO); ProfiNet (PN); Sercos (SE); EtherCat (EC); Ethernet IP (EI); PowerLink (PL)

Electrical connection: "Standard; with jog keys; 1 connector Y-encoded or 1 connector Y-encoded with jog keys"

Protection Class: IP65

Motor: EC-motor

Supply Voltage: 24 V DC $\pm 10\%$ galvanically separated between control and motor and bus

Measurement System: Absolute, optical-magnetic

Accuracy: $\pm 0.9^\circ$

Intermittence: 20% (basis time 600 s)

Manual Adjustment: No

Brake: No

Material: Stainless steel housing. See pdf for details.

Performance Curve - Direct Drives PSS

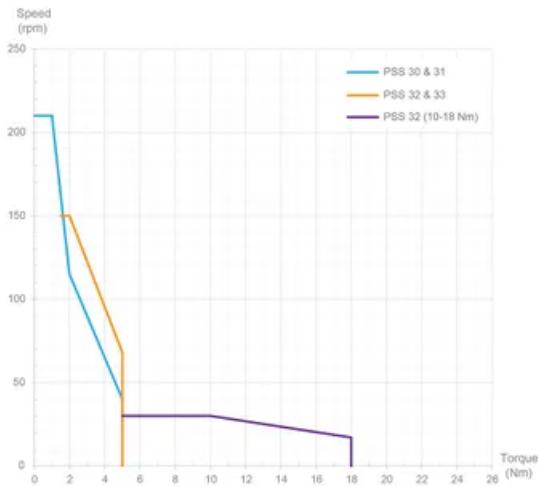

General Data

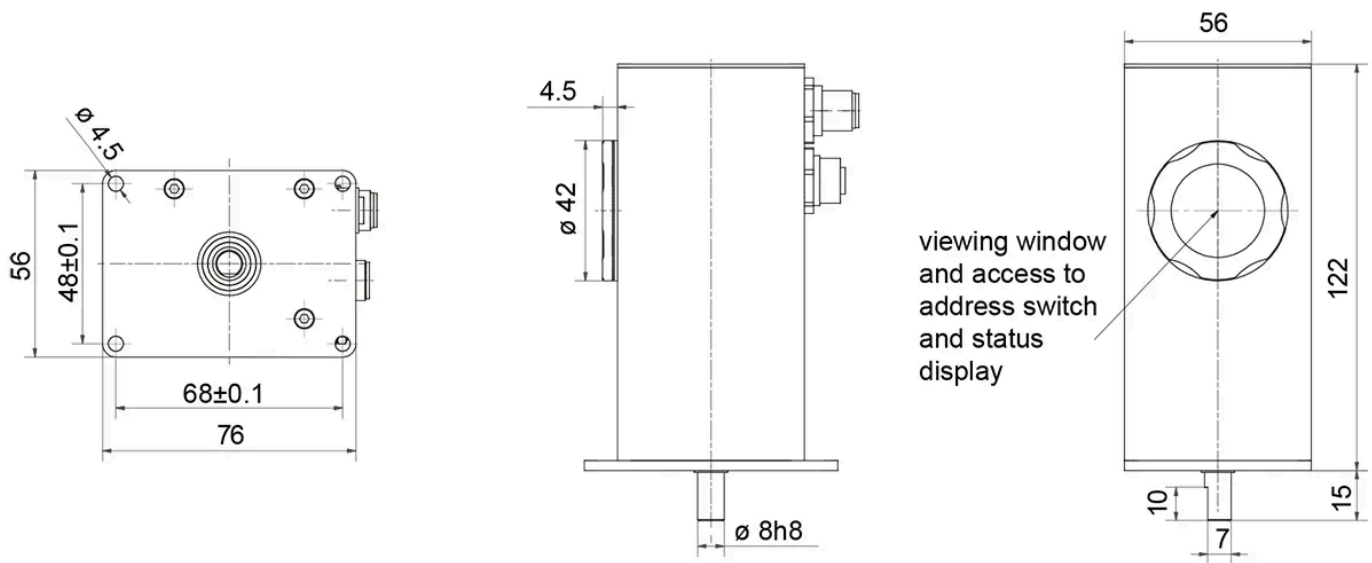

Designation	Nominal Torque (Nm)	Nominal Speed (rpm)	Nominal Current (A)	Self-holding Torque (Nm)	Positioning Range (rot.)
PSS 311-8V	1	210	2.2	0.5	250
PSS 312-8V	2	115	2.2	1	250
PSS 315-8V	5	40	2.2	2.5	250