

Belts

The standard belt for our Timing belt conveyors is a white TPU with steel cord that is covered on the tooth side with a polyamide fabric to reduce noise and friction.

The profile of the belt is the well proven AT10 for both TB40 and TB80.

Option with coating, cleats, and false teeth.

Belt tension is easily adjusted with open screws on the slave/return side.

Dimensions in mm.

For other type of belt requirements please contact Rollco.





Standard TPU



Green polyamide fabric



Standard TPU + Coating Linatex

Standard TPU with cleats
*coating not possible

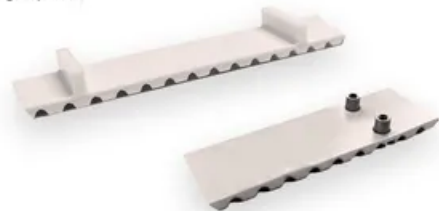

Standard TPU with false teeth
*coating not possible

Belt tension



*Belt is always properly tensioned upon delivery

General Data

Designation	Type	Tooth	Material	Colour	Material Tooth Side
Belt-A	Standard	AT10	TPU	White (Top surface)	PA fabric green
Belt-B	Standard + Coating	AT10	TPU + Linatex 2mm	Red (Top surface)	PA fabric green
Belt-C	Standard + Coating	AT10	TPU + Linatex 4mm	Red (Top surface)	PA fabric green
Belt-A-CL	Standard + Cleats	AT10	TPU + Bonded PU	White (Top surface)	PA fabric green
Belt-A-CM	Standard + Cleats	AT10	TPU + Bonded PU	White (Top surface)	PA fabric green
Belt-A-CH	Standard + Cleats	AT10	TPU + Bonded PU	White (Top surface)	PA fabric green
Belt-A-FT	Standard + False Teeth	AT10	TPU + Stainless steel	White (Top surface)	PA fabric green

Designation	Timing Belt Conveyor	Cleat Size (HxWxT)	C/C Cleats/False Teeth
Belt-A	TB40/TB80	-	-
Belt-B	TB40/TB80	-	-
Belt-C	TB80	-	-
Belt-A-CL	TB40/TB80	10x32x4	See CAD-configurator
Belt-A-CM	TB40/TB80	20x32x4	See CAD-configurator
Belt-A-CH	TB40/TB80	30x32x4	See CAD-configurator
Belt-A-FT	TB40/TB80	See drawing	See CAD-configurator

False Teeth Data

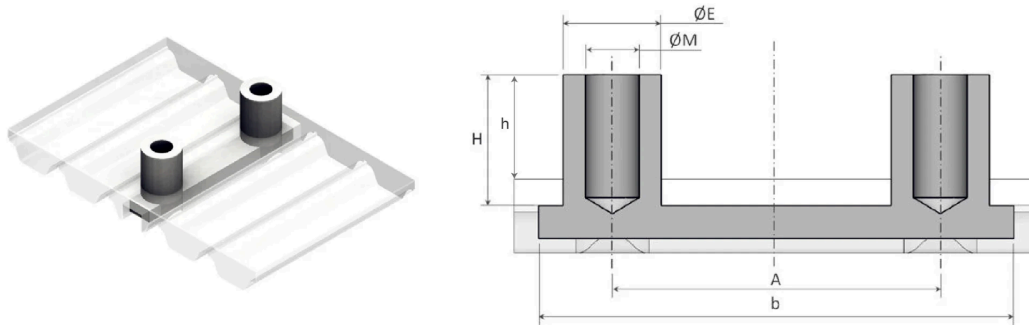

Designation	b	ØE	Thread ØM	H	h
Belt-A	-	-	-	-	-
Belt-B	-	-	-	-	-
Belt-C	-	-	-	-	-
Belt-A-CL	-	-	-	-	-
Belt-A-CM	-	-	-	-	-
Belt-A-CH	-	-	-	-	-
Belt-A-FT	29	6	M4x8	8	6

Designation	A
Belt-A	-
Belt-B	-
Belt-C	-
Belt-A-CL	-
Belt-A-CM	-
Belt-A-CH	-
Belt-A-FT	20