

TB80 Single Timing Belt Conveyor

Single Timing Belt Conveyor with end drive. Options such as cleats, false teeth and coated belt. Stand 100% compatible with conveyor available as an option. Inclination or declination of +/- 10° is possible. For dimensions outside our standard range, please contact Rollco.

Note: Please see load/speed diagram for current values. Use our CAD configurator to design your timing belt conveyor according to your preferences and get a visual view, download data sheet and CAD files.



TB40 and TB80 have been extensively tested over its full performance range of speeds, loads, and lengths, together with our standard drive units.

Declaration of incorporation of partly completed machinery according to Directive 2006/42/EC Annex II 1B.

Dimensions in mm.

Speed (m/min): Up to 54

Drive side: Left/Right

Incline/decline: +/- 10°

Load capacity (kg): 100

Load capacity/m (kg): 100

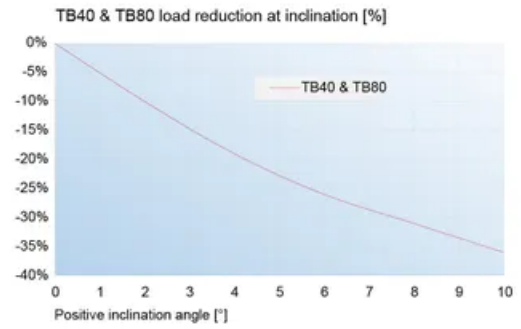
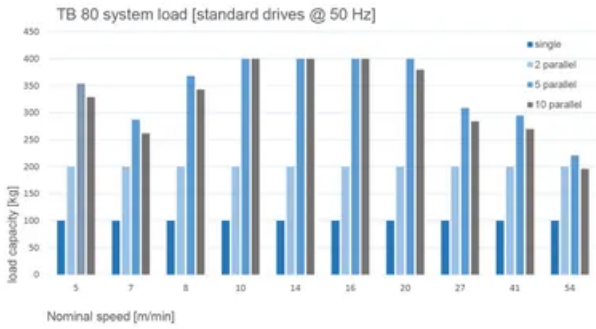

General Data

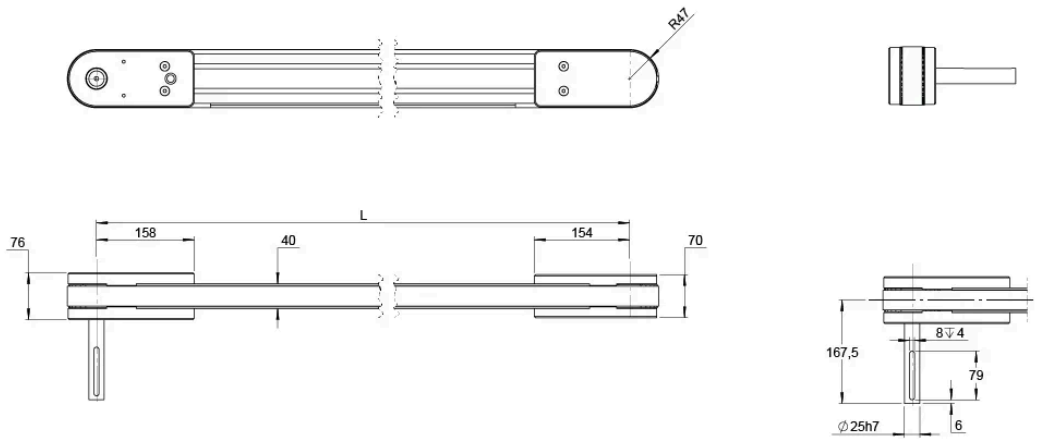

Designation	Profile Width	Profile Height	Belt Width	Total Length (L)
TB80-single	40	80	32	max 6000