

## Conveyor Stand TB40 Double

Aluminium profile stand to match Rollco Timing belt conveyors. Available with adjustable fixable feet. Configure your stand together with the timing belt conveyor in our CAD-configurator.

Values shown under "General data" indicates min and max values in mm according to our standard configurations. For other designs, please contact Rollco.



## General Data

Stand TB40 Double Timing Belt Conveyor

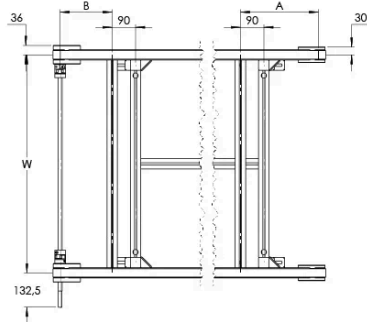

Stand TB40 Double Timing Belt Conveyor  
390 ≤ E, D ≤ 650

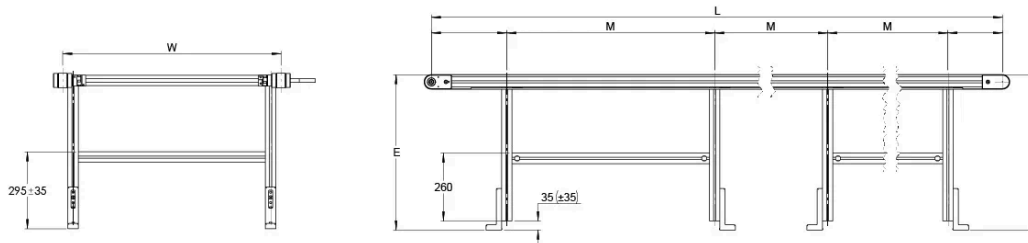

Stand TB40 Double Timing Belt Conveyor  
650 < E,D ≤ 900

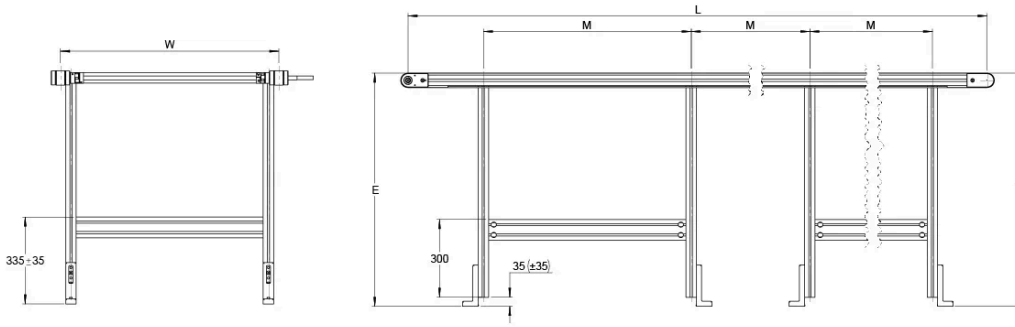

Stand TB40 Double Timing Belt Conveyor  
900 < E,D ≤ 1200

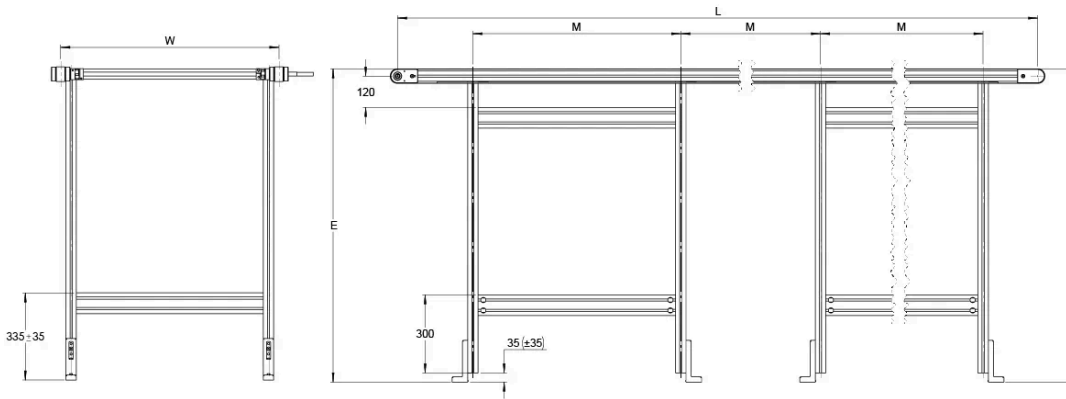

Designation	Profile Width	Profile Height	Total Length (L)	Total Width (W)	CC (w)
<b>TB40-double-stand</b>	40	40	max 6000	max 1500	max 1500

Designation	No. of parallel units	A	B	D	E	M
<b>TB40-double-stand</b>	2	235–390	100–110	390- 1200	390- 1200	160-1000