

Universal Fastener

Application:

Universal fastener that links two aluminium profiles.

Assembly:

Bore hole for the fastener housing:

Ø 20 mm, 20 mm from the profile end, 16 mm deep.

Insert T-nut into the slot of profile and tightened the cylinder screw.

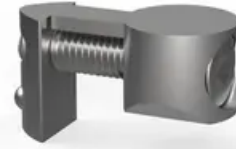

Supply:

Set of universal fastener with guide lug and 8 mm hole. M8 slot nut and MC6S ISO4762 screw included.

Material: Die-cast zinc

System: 40 - Slot 8

Type: Fasteners



Machining:
 Drill hole (a) \varnothing 20 mm
 Drill hole (a1) \varnothing 7 mm
 Distance (b) 20 mm
 Depth (c) 16 mm

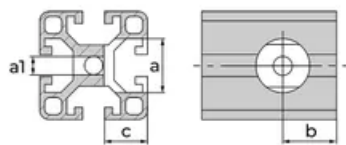

General Data

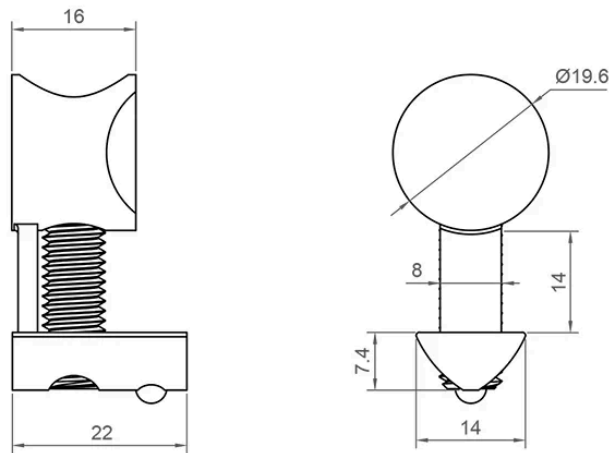

Designation	Description	System	Fmax (N)	Mmax (Nm)
RF1015	Universal Fastener Set 8 with lug	40 - Slot 8	1750	80