

Automatic Fastening Set 40

Application:

The automatic fastening set is quick and easy to use without modifying the profiles. We recommend installing them in pairs - this is also what the stress data refers to.

Assembly:

Insert the cylinder head screw into the profile slot. Screw the self-tapping hollow screw into the profile slot on the face side. Use a lubricant for this. Mount the slot nut into the profile and tighten the cylinder screw.

Supply:

M6 slot nut and MC6S ISO4762 screw included.

Material: Zinc plated steel

System: 40 - Slot 8

Type: Fasteners





Cap for slot 8 automatic connector

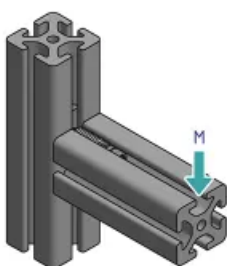
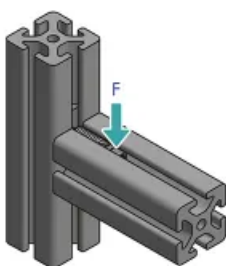

General Data

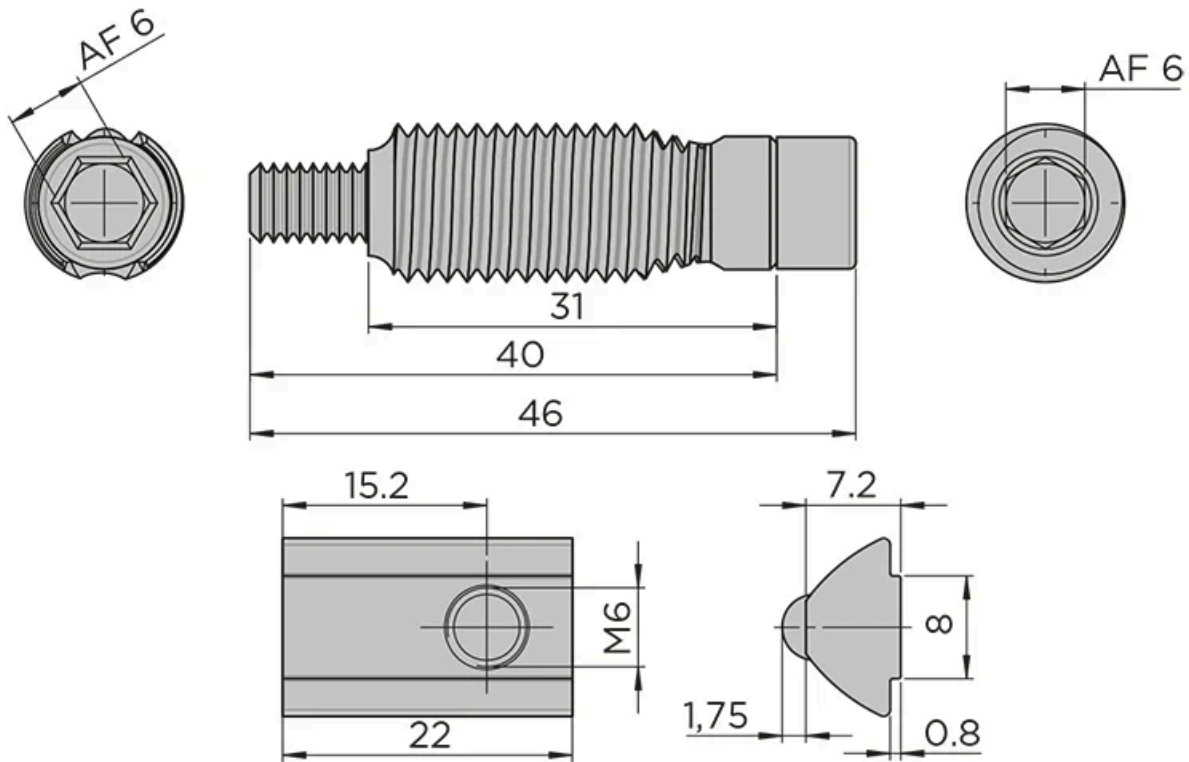

Designation	Description	System	Material	Colour	Slot
RF1102	Automatic connector including slot nut with notched guide step	40 - Slot 8	Zinc plated steel	-	8
RF1101	Cap for slot 8 automatic connector	40 - Slot 8	Plastic (PA)	Grey RAL7042	8

Designation	Fmax (N)	Mmax (Nm)
RF1102	1500	80
RF1101	-	-