

Swivel Castors, Bolt Hole

Housing made of Polyamide, precision ball bearing in swivel head, bolt hole.

Wheel centre made of Polyamide.

Tread made of Polyurethane, precision ball bearing.

Standard: EN 12530

Hardness of tread: Shore A 92

Material: Polyamide

System: 40 - Slot 8; 30 - Slot 6; 20 - Slot 5

Temperature range (°C): -10° to +40°

Type: Castors



General Data

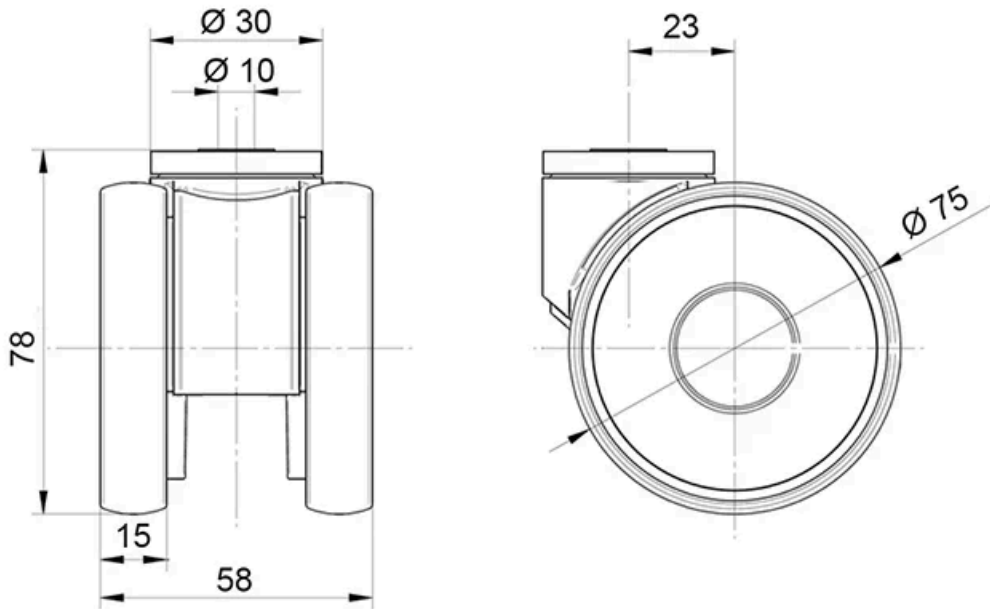

Designation	Description	Wheel Diameter (mm)	Colour	Weight (g)	Swivel Interference (mm)
RA1542	Swivel castor with bolt hole	75	RAL9002	216	121

Designation	Load capacity (kg)	Static Load Capacity (kg)
RA1542	90	180