

Swivel Castors, Bolt Hole with Lock

Housing made of Polyamide, precision ball bearing in swivel head, bolt hole.

Wheel centre made of Polyamide.

Tread made of Polyurethane, precision ball bearing.

Standard: EN 12530

Hardness of tread: Shore A 92

Material: Polyamide

System: 40 - Slot 8; 30 - Slot 6; 20 - Slot 5

Temperature range (°C): -10° to +40°

Type: Castors





General Data

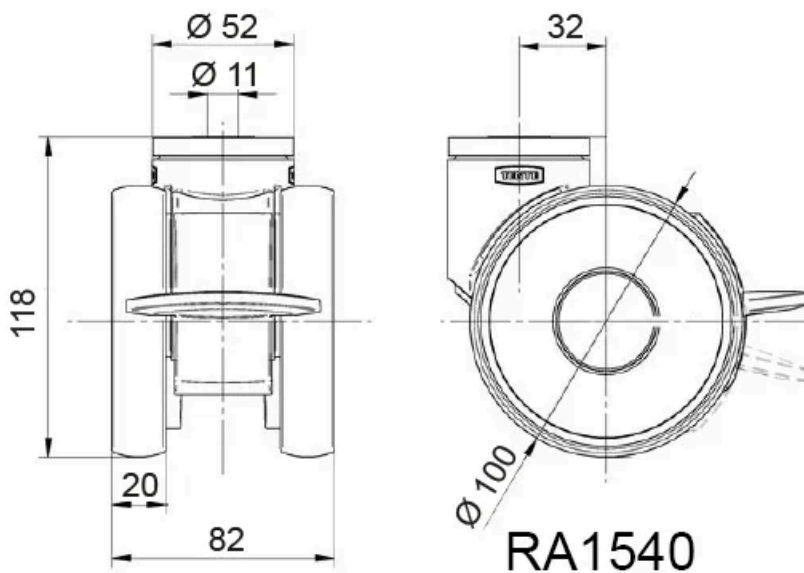
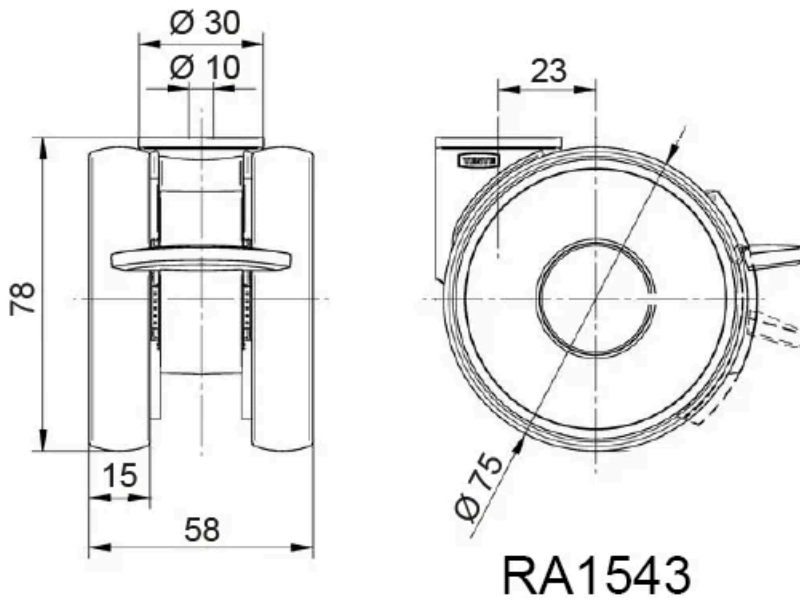

Designation	Description	Wheel Diameter (mm)	Colour	Weight (g)	Swivel Interference (mm)
RA1543	Swivel castor with wheel brake, bolt hole	75	RAL9002	237	156
RA1540	Swivel castor with total lock, bolt hole	100	RAL9002	750	216

Designation	Load capacity (kg)	Static Load Capacity (kg)
RA1543	90	180
RA1540	100	200